



Attn: Builders, Developers and Home owners

RE: New Residential Construction & Accessibility of Electric Utility Meter

To Whom It May Concern,

Due to the flooding experienced during Hurricane Florence, Brunswick Electric Membership Corporation (BEMC) has received many inquiries regarding the placement of electric utility meters in relation to the Base Flood Elevation (BFE). This letter and the accompanying policy are intended to address any questions you may have regarding this topic.

In February 2017, FEMA published a document entitled *Protecting Building Utility Systems from Flood Damage*, in which they suggest placing the meter, service disconnect and main service panel (if separate from the service disconnect) above the BFE. However, BEMC's Service Rules and Regulations state that "the meter location must be easily accessible to the Cooperative personnel or agents." The primary reason for this regulation is to create a safe working environment for BEMC employees who are periodically required to access the metering equipment.

This dilemma is addressed in section 4.2.2.1 of the FEMA document, where it recommends that owners, developers, or local authorities interested in elevating a meter coordinate with their local authorities interested in elevating a meter coordinate with their local utility to ensure they meet the utility's access criteria. Therefore, BEMC has created the accompanying policy to outline our access requirements at locations where the meter is located greater than six feet above grade.

If you have any questions, please call (910)754-4391 and ask to speak to Clayton Rivenbark.

Cooperatively,

Bradley Narron, PE
Engineering Supervisor, Brunswick EMC



Brunswick Electric Membership Cooperative Electric Meter Placement in a Designated Flood Zone

Brunswick Electric Membership Cooperative does not require electric meter and main disconnect be placed above flood levels. The following requirement must be followed if the local governmental agency requires the electric meter to be placed above flood levels.

Access Requirements

To ensure that BEMC meter service and line workers have safe access to BEMC's electric meter, fixed stairs and a landing must be provided for any meter socket located greater than six feet above grade. To ensure that BEMC service personnel are able to work on the panel, an adequately sized work area must be provided. This work area must be a minimum of 48 inches wide by 48 inches deep centered on the meter. If the stairs are directly behind the meter, a movable guard must be installed to block a worker facing the meter from stepping backwards onto the stairs.

The electric meter may be located where fixed outside stairs have been constructed, including stairs that lead to a landing on a porch or deck serving either a front or rear entrance of the dwelling. If BEMC determines that the meter is to be installed on the side of the residence or on a part of the building that is not served by the stairs, then stairs that comply with the requirements of the North Carolina Building Code and Brunswick, Columbus, Robeson, Bladen County code with a landing that meets the size of the work area designated in this guidance will be required to be constructed and maintained in good and sound conditions and may not be removed. Either the removal of or failure to maintain the stairs, landing and work area that provide access to the electric meter could result in discontinuance of electric service.

Building Requirements

The construction of the stairs and landing are subject to the North Carolina Building Codes and the Brunswick, Columbus, Robeson, and Bladen County Code.

For detached one- and two-family dwellings and attached single-family townhouses, the minimum tread depth is 9 inches and the maximum riser height is 8.25 inches. For all other buildings, the minimum tread depth is 11 inches, and the maximum riser height is 7 inches.



When the landing is more than 30 inches above the adjoining grade, guardrails, not less than 36 inches in height are required. The stairs must have a handrail on at least one side and must be mounted between 34 and 38 inches in height. The stairs must be a minimum of 27 inches in width.

Electrical Requirements

The installation must comply with applicable requirements of the National Electrical Code (NEC), the North Carolina Building Code and all of Brunswick, Columbus, Robeson, Bladen and county code requirements.

Bradley Narron, P.E.
Engineering Supervisor, Brunswick EMC

* 200A SERVICE

* IF SERVICE IS GREATER THAN 320A 4X4 PLATFORM IS REQUIRED

* MIN 27" STAIR WIDTH

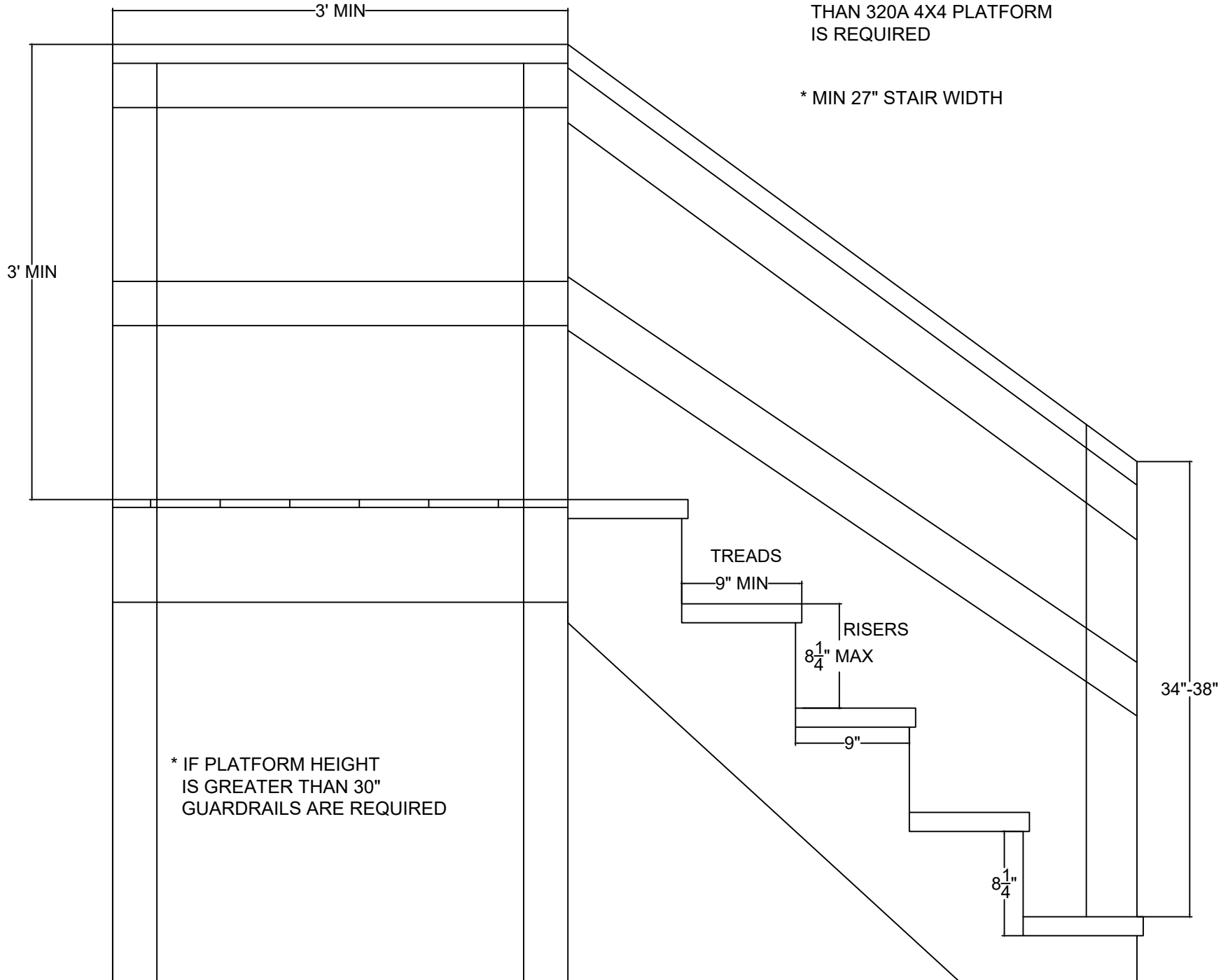

* IF PLATFORM HEIGHT IS GREATER THAN 30" GUARDRAILS ARE REQUIRED

SHIP STAIRS

* 200A SERVICE

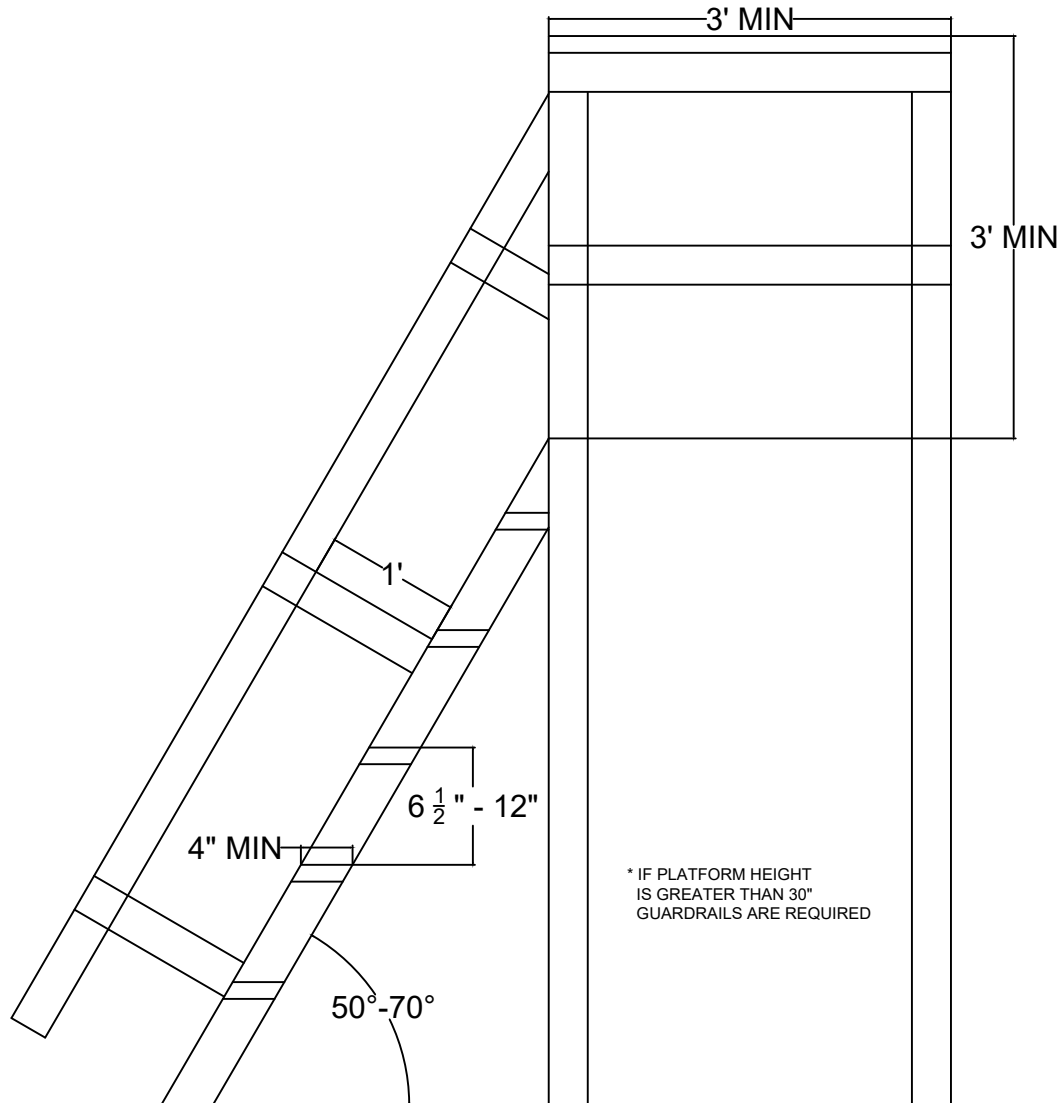

* IF SERVICE IS GREATER THAN 320A 4X4 PLATFORM IS REQUIRED

* MIN 18" TREAD WIDTH

* IF PLATFORM HEIGHT IS GREATER THAN 30" GUARDRAILS ARE REQUIRED